

CheckMark^{®†} Paint Sludge Dryer

The CheckMark[®] Paint Sludge Dryer offers cost effective, automated and continuous paint sludge consolidation, and dewatering. ALSI equipment designs are compatible with all suspension/flotation chemical programs.

The ALSI team of experts have been installing CheckMark[®] Sludge Dryers since the 1980's. This experience and knowledge allow for precise designs that fit our customers exact needs.

Optimize scrubber efficiency by capturing maximum solids in recirculation water thereby returning only clean water to paint booths.
Dry sludge for recycling/disposal.
Minimize paint booth downtime for cleaning.



Single fan design
(high volume, low temperature)



Dual fan design
(high volume, high temperature)

Benefits

- Dewatering up to 60% solids by weight.
- Energy recovered heat source up to 140°F maintains safe, controlled drying environment.
- Automatic operation with minimal operator intervention.
- Reduce disposal costs by removing and reusing water.
- Reduce ambient noise with a sound enclosure.

Optional Features

- Customizable Control System.
- Media Separation System.
- Stainless steel wetted surface construction.
- Gravity, single and dual vacuum designs available.

System Operation

Consolidated paint sludge enters the LPZ (1) and continues to coagulate via polymer chemistry (2) on the media (3). The media is supported by a permanent flat-wire belt (4). The side-seals protect the flat wire belt from the paint sludge, minimizing maintenance. As sludge cake builds to optimum thickness, the automatic level control (5) initiates the automatic media index cycle.

The media drive motor (6) is energized and as clean media is pulled into the system, the media with drying sludge rides up onto the heated (optional) drying ramp (7) into the DRZ. A doctor blade (8) sets the height and spreads the sludge cake, assuring even drying.

The drying force is a high temperature/low volume vacuum producer (11) extracting liquid from the LPZ,

which is then drained back to process or to waste water treatment. The inlet side of the compressor is protected by a stainless steel mist eliminator (9).

The air flow from the high temperature/low volume vacuum producer (11) and from the low temperature/high volume vacuum producer (10) transfer heat to the mixing box (12). Constant drying temperature is controlled through adjustment of two valves (13). By controlling the discharge pressure, a constant temperature is maintained for sludge drying.

Air is blown to the AUZ for even sludge drying. Optional Media Separation System (14) separates media from sludge for individual disposal.

Layout example -
Dual vacuum producer with heat of compression

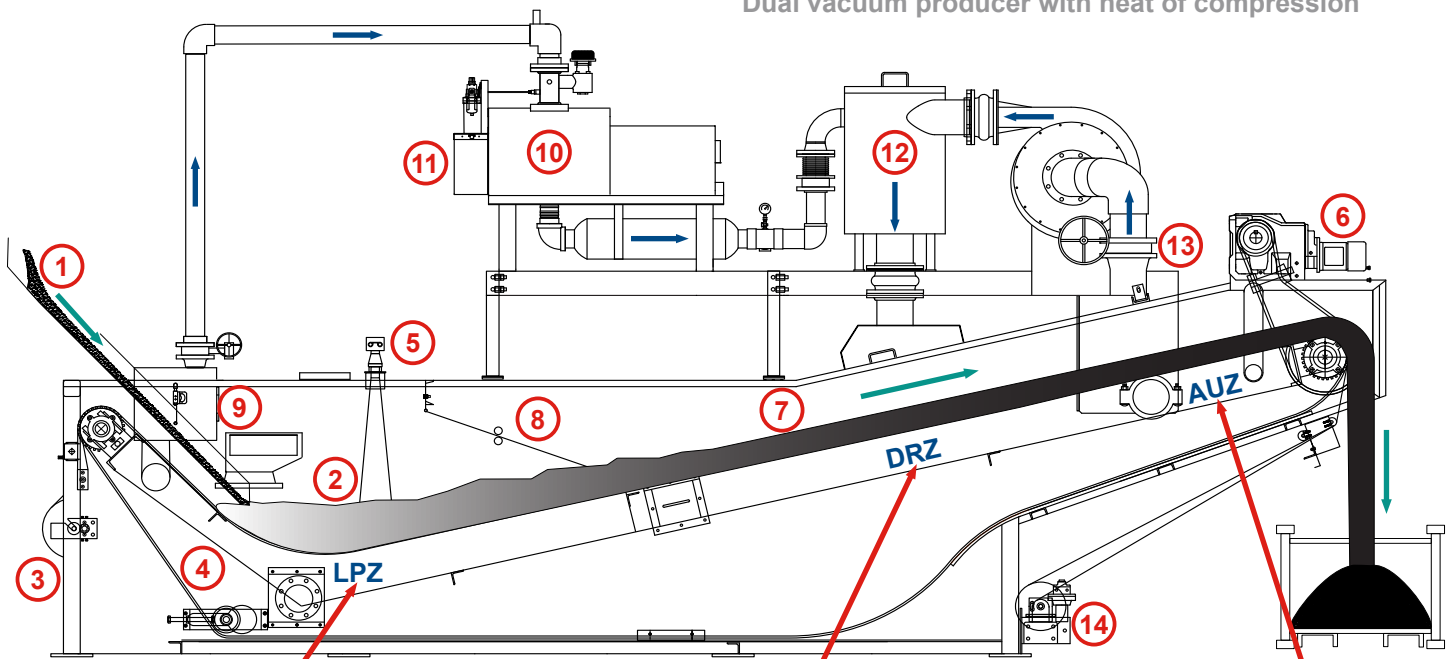

Liquid Pool Zone (LPZ)

Allows for variable sludge feed rates and adequate residence time for solids coagulation and the vacuum extraction of free water.

Drying Ramp Zone (DRZ)

Enhances water removal utilizing heated air flow down and across the sludge cake, producing dewatering efficiencies as high as 60% solids by weight.

Air-Under Zone (AUZ)

Ensures even drying of the sludge cake as air is blown to the underside of the media.

Scan here to visit
our website.

